

# ZN341V+/ZN141V+

## Zone Controller



Automated Logic's ZN341V+/ZN141V+ are designed for a variety of pressure-independent VAV applications. These advanced controllers feature an integral actuator, advanced precision air-flow sensor, flexible connectivity to the full line of RS sensors, and easy-to-use air balance routines. Sophisticated pre-engineered control algorithms reduce energy consumption, maximize actuator life, and ensure occupant comfort. The ZN series controllers are fully programmable and provide networked peer-to-peer communications using native BACnet-over-ARCNET 156 Kbps or MS/TP.

### Key Features and Benefits

- Optimized design for all types of pressure independent VAV applications including cooling only, cooling with modulated hot water re-heat, cooling with electric re-heat, constant volume boxes and dual duct boxes.
- Uses a high speed 16-bit microprocessor with 1 MByte Flash memory and 512 KByte of RAM for graphical programming, diagnostic trends, and easy firmware upgrades using remote downloading - no chip replacement necessary.
- Built-in 0-10 V-dc AO for baseboard or re-heat valve actuator.
- Compact and rugged design for easy mounting and an integral brushless actuator for reliability and longevity.
- The combination of the precision air flow sensor and advanced VAV algorithm assures occupant comfort both at minimum and maximum design air flows, while maximizing actuator life.
- Compatible with the ZASF integral air flow sensor/actuator assembly for dual duct applications.
- Rnet port supports Automated Logic's line of RS room sensors and provides local access to the system.
- The ZN341V+/ZN141V+ controllers are fully graphically programmable and offer full peer-to-peer communications with other ZN line, ME line or SE line controllers. Graphical programs are universally understood and provide self-documenting control sequences.
- Easy-to-use test and balance program via RS sensor or Rnet connection.



**AUTOMATEDLOGIC**

# ZN341V+ / ZN141V+

## Specifications

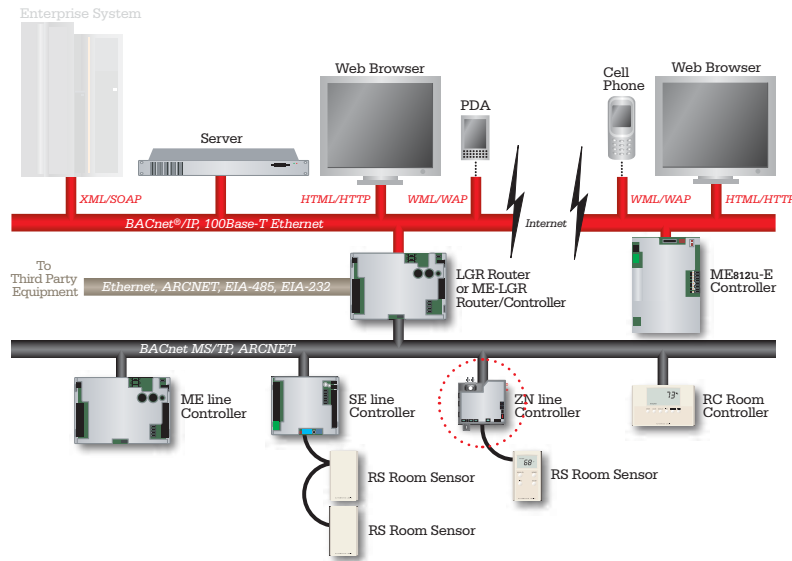

BACnet Support:	Conforms to the Advanced Application Controller (B-AAC) Standard Device Profile as defined in BACnet 135-2001 Annex L.
Communication:	The following ports are available on the ZN 341v+/ZV141v+ modules: EIA-485 port for ARCNET 156 Kbps or MS/TP (9600 bps – 76.8 Kbps). Local access port for system start-up and troubleshooting. Rnet port for RS room sensors – the Rnet port supports up to four RS Standard sensors and one either RS Pro sensor or RS Plus sensor for averaging or high/low select control.
Integral Air Flow Sensor:	Precision low flow AWM series 0-2" W.C., sensitive down to ±0.001" W.C. Barbed tapered air flow connections 3/16" (4.75mm) I.D. tubing.
Integral Actuator:	Brushless DC motor, torque 35 inch-pounds (4Nm), 5 sq.ft. (0.46m <sup>2</sup> ) maximum damper size. Both the ZN341v+ and ZN 141v+ are compatible with the optional ZASF integral air flow sensor/actuator assembly for dual duct applications.
Digital Outputs:	ZN141v+ has one digital output, ZN 341v+ has three digital outputs. Relay contact rated at 1A max @ 24V-ac/V-dc, configured normally open.
Universal Inputs:	Four inputs with 10 bit A/D resolution. Four inputs are configurable for dry contact and type 2 thermistors. Inputs 1 and 2 are also configurable for 0 to 5 V-dc. Inputs 3 and 4 are taken when a LogiStat sensor is connected – these inputs are available if RS sensors are used.
Analog Outputs:	One analog output, 0 to 10 V-dc (5mA maximum) with 8-bit resolution.
Microprocessor:	High speed 16-bit microprocessor with ARCNET communication co-processor.
Memory:	512 KByte non-volatile battery-backed RAM, 1 MByte Flash memory, 16-bit memory bus. (Shelf life of the battery is 10 years with 10,000 hours of continuous operation.)
Status Indicators:	LED status indicators for EIA-485 communication, running, error, power and all digital outputs.
Module Addressing:	Rotary dip switches for intuitive network addressing of modules.
Protection:	Built-in surge and transient protection circuitry for communications.
Listed by:	UL916 (Canadian Std C22.2 No. 205-M1983), CE, FCC Part 15 – Subpart B – Class A
Environmental Operating Range:	0°F to 130°F (-17.8°C to 54.4°C); 10 to 90% relative humidity, non-condensing. NOTE: Control modules must be installed within the building.
Power Requirements:	24V-ac ± 10%, 26V-dc (25 V min, 30 V max), 50 to 60Hz, 14 VA
Physical:	UL94-5VA plenum rated enclosure.
Weight:	1 lb. 11 oz. (0.8 kg)

Dimensions:	<b>Overall</b> Width: 6-1/2" (165mm) Height: 7" (178mm) Depth: 2-1/2" (64mm) min. panel depth	<b>Mounting*</b> One mounting hole as shown at left with 5-5/8" (143mm) spacing (height) from shaft centerline.  *For indoor use only.
-------------	--	---

