

LGR line

High Speed Ethernet Router

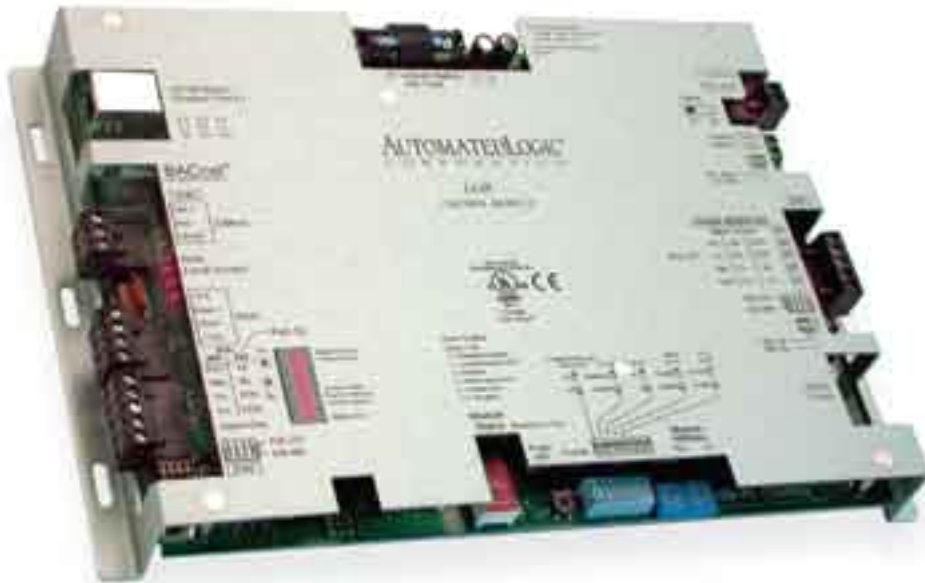

The LGR is an extremely powerful, high-speed router/gateway that can connect hundreds of control modules to a BACnet®/IP backbone. Support for BACnet/IP, BACnet-over-Ethernet, ARCNET 156 Kbps, MS/TP, and BACnet PTP communications are standard. A wide range of open and proprietary protocol translator drivers allow the LGR to also serve as a gateway to other manufacturers' equipment. Fully programmable, the LGR can also execute complex control strategies for high-level system integration.

Key Features and Benefits

- 10/100Base-T Fast Ethernet allows modules to serve as a BACnet router between BACnet/IP system backbone and field devices subnetwork.
- Native BACnet communications to field devices over a high-speed ARCNET 156 Kbps or BACnet MS/TP network.
- Can route messages from BACnet/IP to BACnet-over-Ethernet, providing compatibility with older BACnet systems.
- A wide range of open and proprietary protocol translator drivers allow the LGR to also serve as a gateway to other manufacturers' equipment.
- Designed with a high-speed true 32-bit microprocessor with cache memory, Fast Ethernet controller, high performance 32-bit serial communications co-processor, and ARCNET communications co-processor, LGR routers have the horsepower to serve the most demanding translation and communications functions.
- Can support hundreds of individual control programs written in ALC's legendary EIKON®-LogicBuilder Graphic Programming Language. LGRs can handle the toughest system integration control programs.
- 16 MByte battery-backed SDRAM (32 bit wide), with 12 MBytes available for use, stores application programs, trends and other data when power is lost.
- 8 MByte Flash memory (32 bit wide) for easy field upgrades over the network.
- Battery backed real-time clock provides true standalone capabilities. LGRs recover from power failures providing full continuity of operations, even when communications are disrupted.
- Rnet port supports Automated Logic's line of RS room sensors and BACview⁶ local operator interface, and provides local access to the system. Enhanced local access is also available on an EIA-232 port.
- Tough construction delivers superior performance and reliability. Control modules are constructed with a rugged aluminum cover which provides optimum electrical protection and noise immunity.



AUTOMATEDLOGIC

LGR line

Specifications

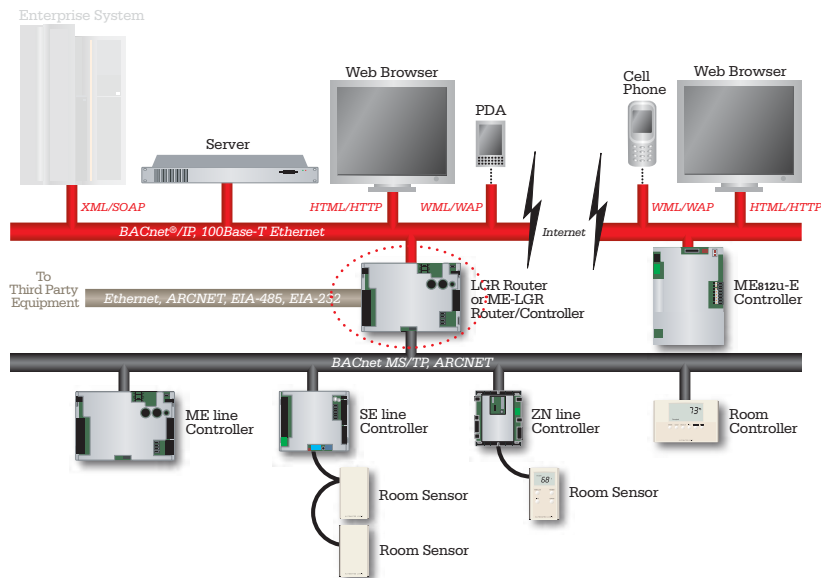

BACnet Support:	Conforms to the BACnet Advanced Application Controller (B-AAC) Standard Device as defined in BACnet 135-2001 Annex L.									
Communication:	The following ports are available on the LGR routers: Ethernet port* (10/100Mbps) for BACnet over Ethernet or BACnet/IP communications. EIA-485 port for ARCNET 156 Kbps or BACnet MS/TP (9600 baud to 76.8 Kbps). EIA-232/485*configurable port for BACnet PTP. Rnet port for RS room sensors and local BACview ⁶ operator displays. Xnet (500Kbps) port for MEX I/O expansion modules. Local access port. <i>*Third-Party integration drivers available through Ethernet and (1) EIA-232/485 configurable port.</i>									
Microprocessor:	32-bit Motorola Power PC microprocessor with cache memory, Fast Ethernet controller, high performance 32-bit communication co-processor, ARCNET communication co-processor and I/O expansion CAN co-processor.									
Memory:	16 MByte non-volatile battery-backed SDRAM (with 12 MBytes available for use), 8 MByte Flash memory, 32-bit memory bus. (Shelf life of the battery is 10 years with 720 hours of continuous operation.)									
Real-time Clock:	Battery-backed real-time clock.									
Status Indicators:	LED status indicators for EIA-232/485 communication, Ethernet port communication, and low battery status. 7-segment status display for running, error, and power status.									
Module Addressing:	Rotary dip switches for intuitive network addressing of modules.									
Protection:	Built-in surge and transient protection circuitry for power and communications.									
Listed by:	UL916 (Canadian Std C22.2 No. 205-M1983), CE, FCC Part 15 - Subpart B - Class A.									
Environmental Operating Range:	-20°F to 140°F (-29°C to 60°C); 10 to 90% relative humidity, non-condensing. NOTE: Control modules should be installed within the building.									
Power Requirements:	24 V-ac ± 10%, 50 to 60Hz, 24 VA, or 26 V-dc ± 10%, 10W. NOTE: Power consumption will increase when BACview ⁶ or other accessories are attached.									
Physical:	Rugged aluminum cover. Removable screw terminal blocks.									
Weight:	1.4 lb. (0.635 kg)									
Dimensions:	<table border="0"> <tr> <td>Overall</td> <td>Mounting</td> </tr> <tr> <td>Width: 11-5/16" (287mm)</td> <td>Width: 10-13/16" (275mm)</td> </tr> <tr> <td>Height: 7-1/2" (190mm)</td> <td>Height: 5" (127mm)</td> </tr> <tr> <td>Depth: 2-3/4" (70mm) min. panel depth</td> <td></td> </tr> </table>	Overall	Mounting	Width: 11-5/16" (287mm)	Width: 10-13/16" (275mm)	Height: 7-1/2" (190mm)	Height: 5" (127mm)	Depth: 2-3/4" (70mm) min. panel depth		
Overall	Mounting									
Width: 11-5/16" (287mm)	Width: 10-13/16" (275mm)									
Height: 7-1/2" (190mm)	Height: 5" (127mm)									
Depth: 2-3/4" (70mm) min. panel depth										

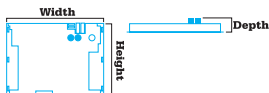

www.carrier.com.hk

© 2007, Automated Logic Corporation. Automated Logic, the Automated Logic logo, EIKON and WebCTRL are registered trademarks of Automated Logic Corporation. BACnet is a registered trademark of ASHRAE. All other trademarks are the property of their respective owners. Specifications are subject to change without prior notice.
A4 CSLGRRev7

