



United Technologies

turn to the experts 



16JL (SINGLE EFFECT STEAM TYPE)

16JLR (SINGLE EFFECT HOT WATER TYPE)

LITHIUM BROMIDE ABSORPTION CHILLER

COOLING CAPACITY : 527~2321 KW (16JL)
239~2321 KW (16JLR)



ISO9001



ISO14001

Carrier makes the world a better place to live by creating a comfortable, productive and healthy environment regardless of climate. It is our mission is to be customer's first choice for air conditioning, heating and refrigeration solutions everywhere around the world.



Great Hall of the People, Beijing, China



Kremlin, Moscow, Russia



White House, Washington, USA



Imperial Palace, Tokyo, Japan

CONTENTS

Features/Benefits	1
Single Effect Cooling Cycle	2
Heat Source and Usage	2
Physical & Performance Data	3
Overall Dimension	7
Foundation Dimension	8
Thermal Insulation	9
Hoisting	10
Specification Scope	11
Wiring Diagram	12
Standard Tubing Flow	14
Water Quality Control	16

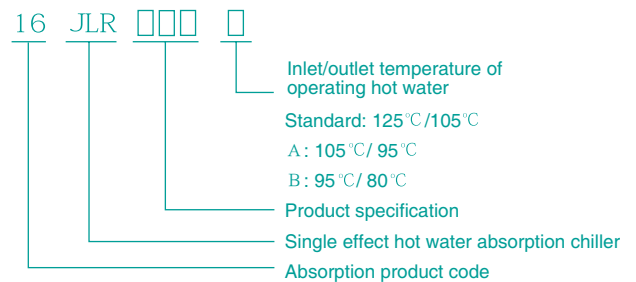

Features / Benefits

- **Environmentally Friendly Chiller**

Using water and lithium bromide which are natural as refrigerant medium, no CFCs; Few moving parts enable quiet and vibration-free operation.

- **Cost-effective cooling alternative-energy chiller**

The 16JL/JLR offers an alternative to avoid the high operating costs associated with electric-driven chillers. Fired by low pressure steam or hot water or waste heat, the 16JL/JLR not only reduces or eliminates electric demand and/or reduce charges, but also allows the owner to take advantage of rebates and incentive programs offered by many utility companies.

- **Superior part load, low cooling water temperature (15°C) operation**

The standard concentration control system allows stable, part load operation at cooling water temperatures as low as 15°C without a cooling tower bypass with Carrier unique refrigerant management system (US patent: US6,260,364-B1), it has a continuous operating range from 100% to 10% of machine capacity.

- **Automatic motorless purge system extends machine life, ensures optimum efficiency and performance**

The Carrier motorless purge system protects against the potential hazards caused by non-condensable gas produced continuously during machine operation, ensures long machine life and efficient operation.

- **Anti-crystallization controls maintain proper solution concentration**

The 16JL/JLR automatically limits solution concentration in several ways to avoid both crystallization and over-dilution to provide dependable, trouble-free operation.

- **Leak-proof hermetic pumps cut maintenance costs**

Carrier's proven solution and refrigerant pumps are leak-proof, completely self-contained, and hermetically sealed. The hermetic design eliminates the need for a separate, complicated, and possibly leak-prone seal water system, while providing leak tightness and longer machine life.

- **Superior corrosion protection**

The 16JL/JLR incorporates a highly effective corrosion inhibitor to provide an extra margin of protection against internal corrosion.

- **Rugged machine construction**

Non-clogging, corrosion-proof spray nozzles ensure against both corrosion and possible blockage for continuous, reliable operation. The 16JL/JLR is built to withstand the most rigorous duty, whether it is used for comfort cooling or light process applications.

- **Single point electrical connection**

All unit-mounted electrical items are factory-wired to the chiller control center and require only a single point electrical connection to the machine from the building's electrical service.

Single Effect Cooling Cycle

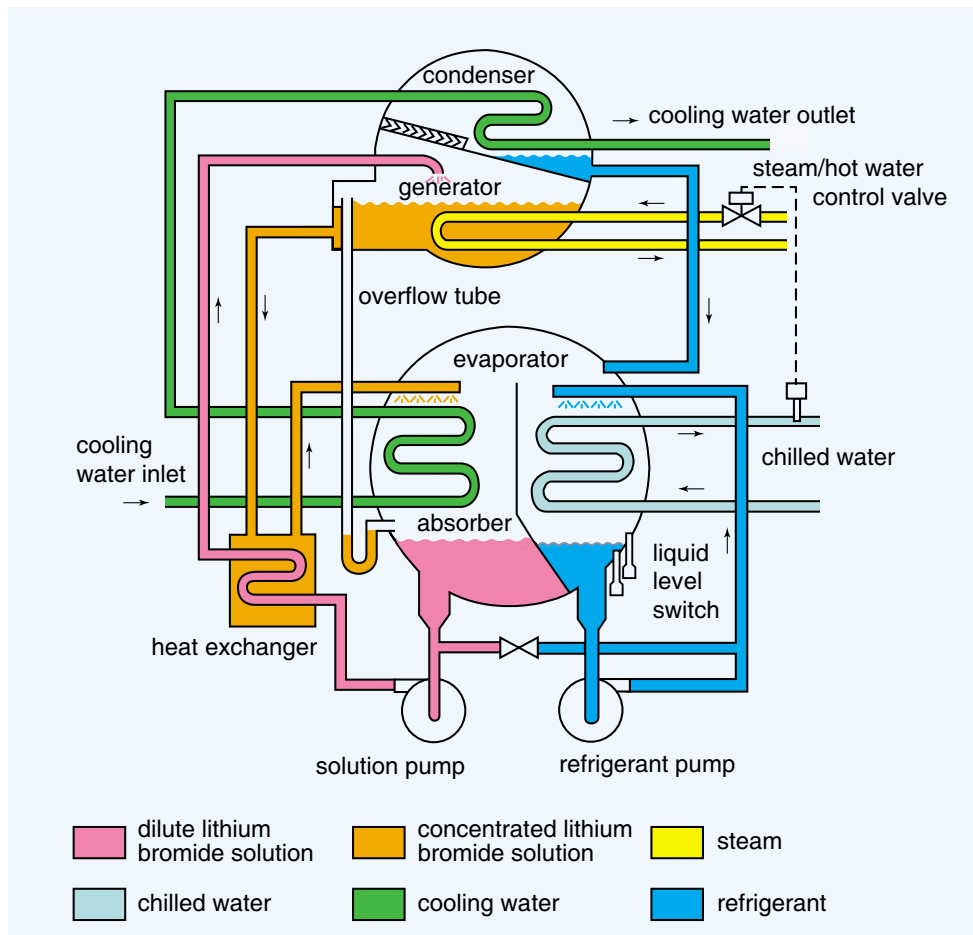

The 16JL/JLR consists of evaporator, absorber, condenser, generator, solution heat exchanger, solution pump, refrigerant pump, control system and other auxiliary system, etc. The operating principle of the chiller is: In highly vacuum state, refrigerant water evaporate at a low temperature (4.4°C), which cool down chilled water circulating in evaporator tube.

Refrigerant vapor generated in evaporator is absorbed by lithium bromide solution in absorber, which makes the solution become dilute. Such dilute solution is fed into heat exchanger by solution pump, where the temperature rises. After that, it enters generator, in which it is further heated and concentrated by steam or hot water. The concentrated solution returns to the absorber after passing through heat exchanger for repeated use. In absorber and evaporator, lithium bromide solution and refrigerant water spray onto tubes of the heat exchangers to enhance heat exchange effect.

Heat Source and Usage

Operating steam: gauge pressure $0.04\sim 0.098\text{MPa}$
(pressure after steam valve).

Operating hot water: Max. temperature 130°C ,
Min. temperature 85°C .

Physical & Performance Data

16JL (Steam pressure: 0.098MPa)

Model	16JL	011	013	015	018	021	024	027	030	034	038	047	052	
Capacity	USRt	150	180	210	240	280	330	360	400	450	500	600	660	
	10 ⁴ kcal/h	45	54	64	73	85	100	109	121	136	151	181	200	
	kW	527.4	632.88	738	844	984	1160	1266	1406	1582	1758	2110	2321	
Chilled water	Inlet/Outlet Temp	°C	12/7											
	Flow Rate	m ³ /h	91	109	127	145	169	200	218	242	272	302	363	399
	Pressure Drop	mH ₂ O	8.8	9.5	8.9	9.0	6.0	6.3	6.2	6.2	6.2	6.3	7.2	9.2
	Connection Size	kPa	86.2	93.1	87.2	88.2	58.8	61.7	60.8	60.8	60.8	61.7	70.6	90.2
		A(mm)	100	100	125	125	150	150	150	150	200	200	200	200
	Pass No.		3	3	3	3	2	2	2	2	2	2	2	2
Cooling water	Inlet/Outlet Temp	°C	32/40											
	Flow Rate	m ³ /h	136	163	190	217	253	299	326	362	407	453	543	597
	Pressure Drop	mH ₂ O	6.9	8.1	5.6	6.4	8.2	8.8	9.7	10.2	8.8	9.2	7.3	9.4
	Connection Size	kPa	67.6	79.4	54.9	62.7	80.4	86.2	95.1	100.0	86.2	90.2	71.5	92.1
		A(mm)	125	125	150	150	200	200	200	200	250	250	300	300
	Pass No.	Absorber	2	2	2	2	2	2	2	2	2	2	2	2
	Condenser	1	1	1	1	1	1	1	1	1	1	1	1	
Steam	Inlet Pressure	Mpa	0.098											
	Consumption	kg/h	1146	1375.2	1604	1834	2139	2521	2750	3056	3438	3820	4584	5042
	Steam Pipe Size	A(mm)	125	125	125	125	150	150	150	150	200	200	200	200
	Drain Pipe Size	A(mm)	40	40	40	40	50	50	50	50	65	65	65	65
Electric	Power Supply	V	3Ø-380V-50Hz											
	Refrigerant Pump	kW	0.4	0.4	0.4	0.4	0.4	0.4	0.8	0.8	0.8	0.8	1.5	1.5
	Solution Pump	kW	2.6	2.6	2.6	2.6	3.7	3.7	3.7	3.7	3.7	3.7	3.7	3.7
	Capacity	kVA	4.5	4.5	4.5	4.5	6.2	6.2	6.8	6.8	6.8	6.8	7.8	7.8
Dimension	Length	mm	3672	3672	3724	3724	4777	4777	4854	4854	4875	4875	5640	6142
	Width	mm	1417	1417	1512	1512	1553	1553	1629	1629	1759	1759	2004	2004
	Height	mm	2300	2300	2573	2573	2639	2639	2904	2904	3106	3106	3464	3464
Weight	Net Weight	ton	4	4.3	6.0	6.5	7.5	8.0	9.0	9.5	10.5	11.0	16.0	17.0
	Operating Weight	ton	5.5	6	8.1	8.5	10.5	11.0	12.5	13.5	14.5	15.0	21.0	22.0

1. The above cooling capacity is based on the following conditions: inlet/outlet temperature of chilled water: 12°C/7°C, cooling water: 32°C/40°C, operating steam pressure: 0.098Mpa, fouling factor (both chilled water and cooling water): 0.086m²°C/kW.
2. Maximum waterside pressure of chilled water and cooling: 0.8MPa.
3. For the performance data under non-standard condition, please contact of Carrier Co. or its representative office.
4. This device could also be shipped in two pieces, please contact of Carrier Co. or its representative office for more details.

Physical & Performance Data

16JLR (Hot water temperature (inlet/outlet):125°C/105°C)

Model	16JL	011	013	015	018	021	024	027	030	034	038	047	052	
Capacity	USRt	150	180	210	240	280	330	360	400	450	500	600	660	
	10 ⁴ kcal/h	45	54	64	73	85	100	109	121	136	151	181	200	
	kW	527	633	738	844	984	1160	1266	1406	1582	1758	2110	2321	
Chilled water	Inlet/Outlet Temp	°C	12/7											
	Flow Rate	m ³ /h	91	109	127	145	169	200	218	242	272	302	363	399
	Pressure Drop	mH ₂ O	8.8	9.5	8.9	9.0	6.0	6.3	6.2	6.2	6.2	6.3	7.2	9.2
	Connection Size	kPa	86.2	93.1	87.2	88.2	58.8	61.7	60.8	60.8	60.8	61.7	70.6	90.2
		A(mm)	100	100	125	125	150	150	150	150	200	200	200	200
	Pass No.		3	3	3	3	2	2	2	2	2	2	2	2
Cooling water	Inlet/Outlet Temp	°C	32/40											
	Flow Rate	m ³ /h	136	163	190	217	253	299	326	362	407	453	543	597
	Pressure Drop	mH ₂ O	6.9	8.1	5.6	6.4	8.2	8.8	9.7	10.2	8.8	9.2	7.3	9.4
	Connection Size	kPa	67.6	79.4	54.9	62.7	80.4	86.2	95.1	100.0	86.2	90.2	71.5	92.1
		A(mm)	125	125	150	150	200	200	200	200	250	250	300	300
	Pass No.	Absorber	2	2	2	2	2	2	2	2	2	2	2	2
	Condenser	1	1	1	1	1	1	1	1	1	1	1	1	
Hot Water	Inlet/Outlet Temp	°C	125/105											
	Flow Rate	m ³ /h	32	38	44	50	59	69	76	84	95	105	126	139
	Pressure Drop	mH ₂ O	4.2	5.3	9.6	9.3	6.4	7.3	7.1	6.9	5.7	5.9	7.8	9.5
	Connection Size	kPa	41.0	51.6	94	92	63	71	70	67	56	57	77	93
		A(mm)	80	80	80	80	100	100	100	100	125	125	125	125
Pass No.		2	2	4	4	3	3	3	3	3	3	3	3	
Electric	Power Supply	V	3Ø-380V-50Hz											
	Refrigerant Pump	kW	0.4	0.4	0.4	0.4	0.4	0.4	0.8	0.8	0.8	0.8	1.5	1.5
	Solution Pump	kW	2.6	2.6	2.6	2.6	3.7	3.7	3.7	3.7	3.7	3.7	3.7	3.7
	Capacity	kVA	4.5	4.5	4.5	4.5	6.15	6.15	6.75	6.75	6.75	6.75	7.8	7.8
Dimension Weight	Length	mm	3672	3672	3724	3724	4777	4777	4854	4854	4875	4875	5640	6142
	Width	mm	1417	1417	1512	1512	1553	1553	1629	1629	1759	1759	2004	2004
	Height	mm	2300	2300	2573	2573	2639	2639	2904	2904	3106	3106	3464	3464
	Net Weight	ton	4	4.3	6.0	6.5	7.5	8.0	9.0	9.5	10.5	11.0	16.0	17.0
	Operating Weight	ton	5.5	6	8.1	8.5	10.5	11.0	12.5	13.5	14.5	15.0	21.0	22.0

1. The above cooling capacity is based on the following conditions: inlet/outlet temperature of chilled water: 12°C/7°C, cooling water: 32°C/40°C, inlet/outlet temperature of hot water:125°C/105°C, fouling factor (both chilled water and cooling water): 0.086m².°C/kW.

2. Maximum waterside pressure of chilled water and cooling: 0.8MPa.

3. For the performance data under non-standard condition, please contact of Carrier Co. or its representative office.

4. This device could also be shipped in two pieces, please contact of Carrier Co. or its representative office for more details.

Physical & Performance Data

16JLR (Hot water temperature (inlet/outlet): 105°C/ 95°C)

Model	16JL	011A	013A	015A	018A	021A	024A	027A	030A	034A	038A	047A	052A	
Capacity	USRt	138	166	193	221	258	304	331	368	414	460	552	607	
	10 ⁴ kcal/h	42	50	58	67	78	92	100	111	125	139	167	184	
	kW	485	582	679	776	906	1067	1164	1294	1456	1617	1941	2135	
Chilled water	Inlet/Outlet Temp	°C	12/7											
	Flow Rate	m ³ /h	83	100	117	134	156	184	200	223	250	278	334	367
	Pressure Drop	mH ₂ O	7.4	8.0	7.5	7.6	5.1	5.3	5.2	5.2	5.2	5.3	6.1	7.8
	Connection Size	kPa	73.0	78.8	73.8	74.7	49.8	52.3	51.4	51.4	51.4	52.3	59.7	76.3
		A(mm)	100	100	125	125	150	150	150	150	200	200	200	200
	Pass No.		3	3	3	3	2	2	2	2	2	2	2	2
Cooling water	Inlet/Outlet Temp	°C	32/40											
	Flow Rate	m ³ /h	126	151	176	201	234	276	301	335	377	419	502	553
	Pressure Drop	mH ₂ O	6.0	6.9	4.8	5.5	7.0	7.5	8.3	8.7	7.5	7.9	6.2	8.0
	Connection Size	kPa	59	68	47	54	69	74	81	86	74	77	61	79
		A(mm)	125	125	150	150	200	200	200	200	250	250	300	300
	Pass No.	Absorber	2	2	2	2	2	2	2	2	2	2	2	2
	Condenser	1	1	1	1	1	1	1	1	1	1	1	1	
Hot Water	Inlet/Outlet Temp	°C	105/95											
	Flow Rate	m ³ /h	58	70	82	93	109	128	140	156	175	195	233	257
	Pressure Drop	mH ₂ O	6.9	7.4	13.6	13.2	6.5	7.4	7.3	7.0	5.8	6.0	8.0	9.7
	Connection Size	kPa	68	73	133	129	64	72	71	69	57	58	78	95
		A(mm)	100	100	100	100	125	125	125	125	150	150	200	200
Pass No.		3	3	3	3	2	2	2	2	2	2	2	2	
Electric	Power Supply	V	3Ø-380V-50Hz											
	Refrigerant Pump	kW	0.4	0.4	0.4	0.4	0.4	0.4	0.8	0.8	0.8	0.8	1.5	1.5
	Solution Pump	kW	2.6	2.6	2.6	2.6	3.7	3.7	3.7	3.7	3.7	3.7	3.7	3.7
	Capacity	kVA	4.5	4.5	4.5	4.5	6.15	6.15	6.75	6.75	6.75	6.75	7.8	7.8
Dimension Weight	Length	mm	3672	3672	3724	3724	4777	4777	4854	4854	4875	4875	5640	6142
	Width	mm	1417	1417	1512	1512	1553	1553	1629	1629	1759	1759	2004	2004
	Height	mm	2300	2300	2573	2573	2639	2639	2904	2904	3106	3106	3464	3464
	Net Weight	ton	4	4.3	6	6.5	7.5	8	9	9.5	10.5	11	16	17
	Operating Weight	ton	5.5	6	8.1	8.5	10.5	11	12.5	13.5	14.5	15	21	22

- The above cooling capacity is based on the following conditions: inlet/outlet temperature of chilled water: 12°C/7°C, cooling water: 32°C/40°C, inlet/outlet temperature of hot water: 105°C/95°C, fouling factor (both chilled water and cooling water): 0.086m²·°C/kW.
- Maximum waterside pressure of chilled water and cooling: 0.8MPa.
- For the performance data under non-standard condition, please contact of Carrier Co. or its representative office.
- This device could also be shipped in two pieces, please contact of Carrier Co. or its representative office for more details.

Physical & Performance Data

16JLR (Hot water temperature (inlet/outlet):95°C/80°C)

Model	16JL	011B	013B	015B	018B	021B	024B	027B	030B	034B	038B	047B	052B	
Capacity	USRt	75	90	105	120	140	165	180	200	225	250	300	330	
	10 ⁴ kcal/h	23	27	32	36	42	50	54	60	68	76	91	100	
	kW	264	316	369	422	492	580	633	703	791	879	1055	1160	
Chilled water	Inlet/Outlet Temp	°C	12/7											
	Flow Rate	m ³ /h	45	54	64	73	85	100	109	121	136	151	181	200
	Pressure Drop	mH ₂ O	5.9	6.5	5.60	5.80	11.30	11.50	11.20	10.90	11.90	11.90	6.10	7.90
	Connection Size	kPa	57.8	63.7	54.9	56.8	110.7	112.7	109.8	106.8	116.6	116.6	59.8	77.4
		A(mm)	80	80	100	100	125	125	125	125	150	150	150	150
	Pass No.		4	4	4	4	4	4	4	4	4	4	3	3
Cooling water	Inlet/Outlet Temp	°C	32/40											
	Flow Rate	m ³ /h	71	85	99	113	132	156	170	189	212	236	283	312
	Pressure Drop	mH ₂ O	10.2	10.5	7.8	7.9	9.6	9.9	10.4	10.5	10.1	10.2	7.5	9.7
	Connection Size	kPa	100	103	76	77	94	97	102	103	99	100	74	95
		A(mm)	100	100	125	125	150	150	150	150	200	200	200	200
	Pass No.	Absorber	4	4	4	4	3	3	3	3	3	3	3	3
	Condenser	2	2	2	2	2	2	2	2	2	2	2	2	
Hot Water	Inlet/Outlet Temp	°C	95/80											
	Flow Rate	m ³ /h	23	27	32	36	42	50	54	60	68	76	91	100
	Pressure Drop	mH ₂ O	2.6	2.6	4.8	4.7	7.8	8.9	8.7	8.4	7.0	7.2	9.6	11.6
	Connection Size	kPa	26	26	47	46	77	87	86	83	69	70	94	114
		A(mm)	65	65	80	80	100	100	100	100	100	100	125	125
Pass No.		4	4	4	4	4	4	4	4	4	4	4	4	
Electric	Power Supply	V	3Ø-380V-50Hz											
	Refrigerant Pump	kW	0.4	0.4	0.4	0.4	0.4	0.4	0.8	0.8	0.8	0.8	1.5	1.5
	Solution Pump	kW	2.6	2.6	2.6	2.6	3.7	3.7	3.7	3.7	3.7	3.7	3.7	3.7
	Capacity	kVA	4.5	4.5	4.5	4.5	6.15	6.15	6.75	6.75	6.75	6.75	7.8	7.8
Dimension Weight	Length	mm	3672	3672	3724	3724	4777	4777	4854	4854	4875	4875	5640	6142
	Width	mm	1417	1417	1512	1512	1553	1553	1629	1629	1759	1759	2004	2004
	Height	mm	2300	2300	2573	2573	2639	2639	2904	2904	3106	3106	3464	3464
	Net Weight	ton	4	4.3	6	6.5	7.5	8	9	9.5	10.5	11	16	17
	Operating Weight	ton	5.5	6	8.1	8.5	10.5	11	12.5	13.5	14.5	15	21	22

- The above cooling capacity is based on the following conditions: inlet/outlet temperature of chilled water: 12°C/7°C, cooling water: 32°C/40°C, inlet/outlet temperature of hot water:95°C/80°C, fouling factor (both chilled water and cooling water): 0.086m².°C /kW.
- Maximum waterside pressure of chilled water and cooling: 0.8MPa.
- For the performance data under non-standard condition, please contact of Carrier Co. or its representative office.
- This device could also be shipped in two pieces, please contact of Carrier Co. or its representative office for more details.

Overall Dimension

16JL / JLR011~052

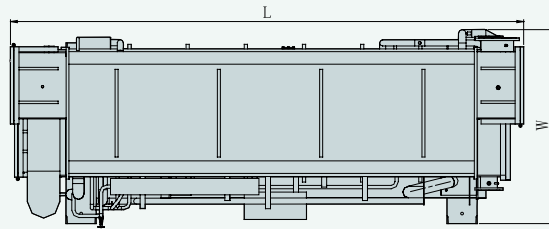

Note:

1. cooling water inlet, steam inlet, hot water inlet shall be located at the front left side.
2. Standard chilled water inlet is located at the left side. Right inlet is optional.
3. Minimum space around chiller shall be
 - "L"m from the chiller in length direction
 - 0.2m from the top of the chiller
 - 1m from the front side of the chiller (beside the control panel)
 - 0.5m from other parts of the chiller

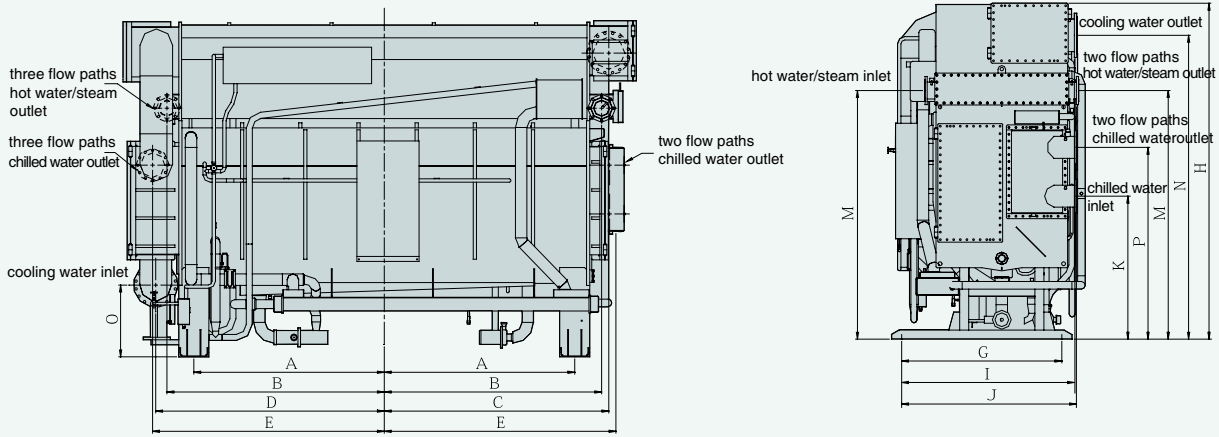

(mm)

16JL/JLR		011	015	021	027	034	047	052
Position		013	018	024	030	038		
Length Width Height	L	3672	3724	4777	4854	4875	5640	6142
	W	1417	1512	1553	1629	1759	2004	2004
	H	2300	2573	2639	2904	3106	3464	3464
	A	1453	1456	1896	1899	1899	2174	2423
	G	743	804	990	1300	1100	1600	1600
Cooling Water	C	1625	1914	2178	2203	2206	2526	2763
	D	1636	1672	2187	2214	2229	2554	2803
	I	828	1016	1080	1410	1308	1729	1729
	O	750	751	710	825	845	770	770
	N	1978	2346	2352	2627	2816	3147	3147
Chilled Water	E	1635	1734	2196	2253	2206	2522	2787
	I	828	1016	1080	1410	1308	1729	1729
	P	1392	1503	1500	1684	1806	1910	1910
	K	1033	1108	1174	1320	1358	1424	1424
Steam (Hot Water)	B	1635	1893	2141	2156	2154	2442	2691
	J	836	988	1082	1375	1305	1748	1748
	M	1850	1950	1950	2200	2300	2468	2468

Foundation Dimension

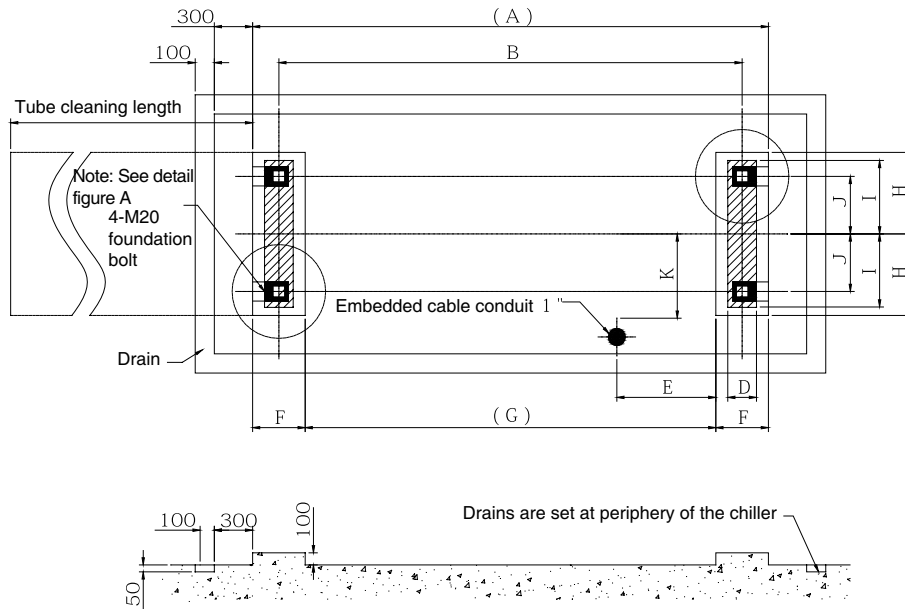

16 JL / JLR007~052

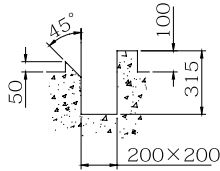

Detail Figure A

Technical requirements:

1. Foundation load bearing capacity of the chiller is designed subject to weight load of the chiller.
2. Foundation levelness is controlled within 1/1000.
3. Square holes in foundation are used to fix foundation bolts. After the chiller is positioned in place, mortar is poured along the slope at one side of the square hole to fix foundation bolts.
4. Shaded portion and square hole represents base corner and foundation bolt hole of the chiller respectively.
5. Space for tube drawing lengthwise may be set at the other side of the chiller.
6. Values in brackets are reference values.

(mm)

Model	A	B	C	D	E	F	G	H	I	J	K
16JL/JLR011/013	3328	2906	3500	150	1277	350	2628	520	420	371.5	671.5
16JL/JLR015/018	3334	2918	3500	150	1280	350	2634	600	500	450	750
16JL/JLR021/024	4292	3792	4500	300	1646	500	3292	700	600	495	795
16JL/JLR027/030	4298	3798	4500	300	1649	500	3298	900	800	650	750
16JL/JLR034/038	4298	3798	4500	300	1649	500	3298	900	800	550	650
16JL/JLR047	4848	4348	4700	300	1924	500	3848	1000	900	800	800
16JL/JLR052	5346	4846	5700	300	2173	500	4346	1000	900	800	800

Thermal Insulation

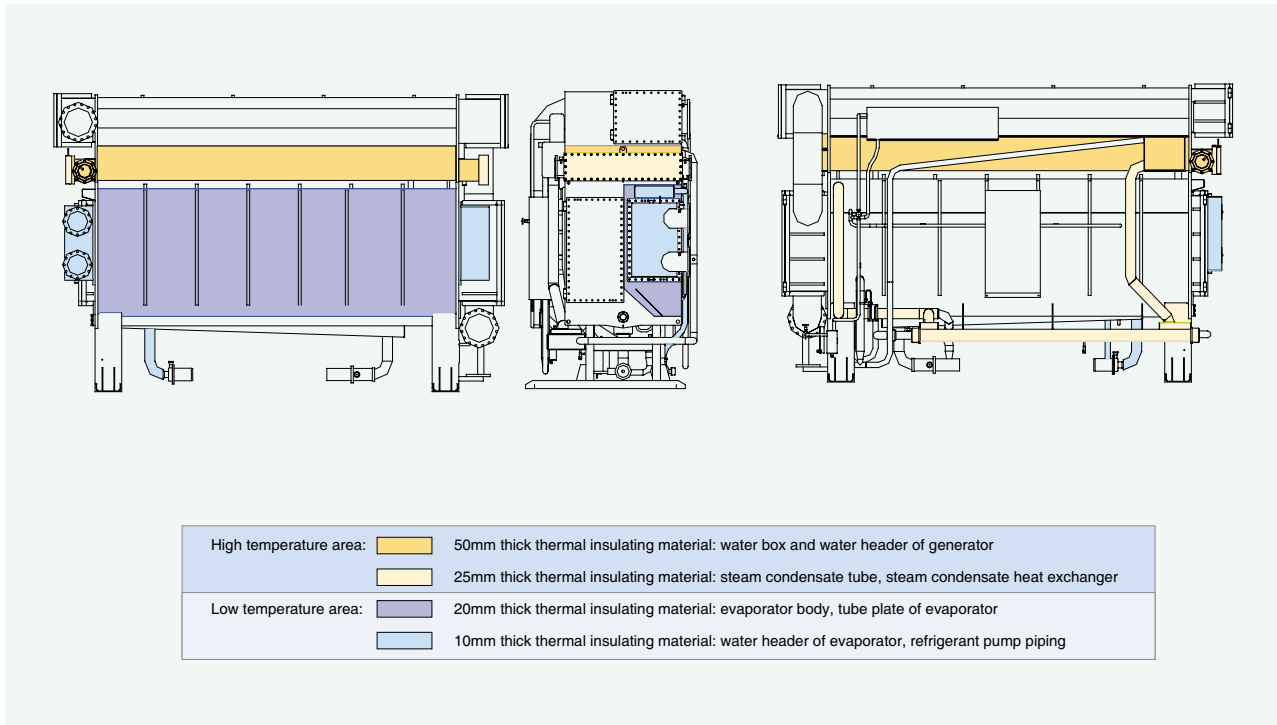

Note:

- After installation and commissioning is completed, thermal insulation shall be made for the chiller to reduce energy loss, improve operating environment and achieve a longer service life.
- Thermal insulating material shall not be inflammable, water absorbent or air permeable.
- Thermal insulation for water box shall facilitate opening/closing of water header during maintenance of tube.
- Control panel and motors of solution pump and refrigerant pump do not require thermal insulation.
- Joint of the thermal insulating material shall be sealed with tape to avoid dampness.
- Bond should be used in installation of thermal insulation . Welding is strictly prohibited.
- Thickness and area of insulating material is shown in the following table.

Thermal insulation area

(m²)

Area	011/013	015/018	021/024	027/030	034/038	047	052
High temp area	10.3	11.5	13.6	15.9	17.2	21.4	23.6
Low temp area	6.3	7	8.8	9.3	10.9	17.2	17.5

Note:

- Material request for high temperature area: glass fibre, asbestos or other similar.
- Material request for low temperature area: cellular polyethylene or other similar.

Hoisting

Single piece installation

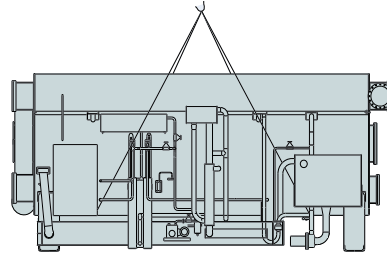
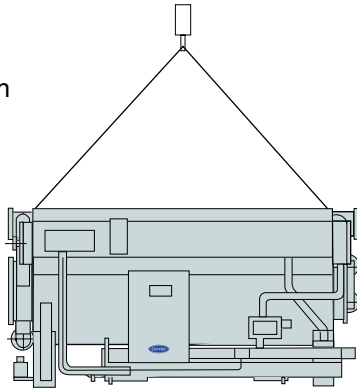

Two-piece installation

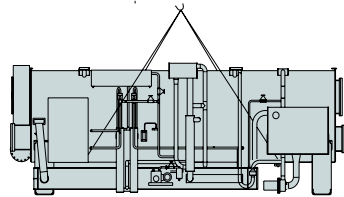
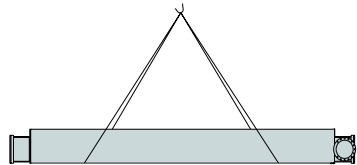

Note: In actual situation, please conduct hoisting according to the hoisting marks adhered to the chiller

Model		011	013	015	018	021	024	027	030	034	038	047	052	
Single piece	Length	mm	3672	3724	3724	4777	4777	4854	4854	4875	4875	5640	6142	
	Width	mm	1417	1417	1512	1512	1553	1629	1629	1759	1759	2004	2004	
	Height	mm	2300	2300	2573	2573	2639	2639	2904	2904	3106	3464	3464	
Shipping weight		t	4	4.3	6	6.5	7.5	8	9	9.5	10.5	11	16	17
Operating weight		t	5.5	6	8.1	8.5	10.5	11	12.5	13.5	14.5	15	21	22

Specification Scope

Item	Standard	Option	
Chilled Water	Flow Rate	ARI, GB & JIS(0.605m ³ /h.RT) Standard	50 ~ 120% Flow Rate
	Ent/Lev Temperature	12°C/7 °C or 54F/44F	Leav. Temperature=5~15°C
	Fouling Factor	< 0.086 m ² ·°C/kW	> 0.086 m ² ·°C/kW
	Max Pressure	10 barG (1.0Mpa)	16 or 20 bar
	Water Quality	Fresh Water	Sea Water or Brine(Ethyleneglycol)
Cooling Water	Flow Rate	ARI, GB & JIS Standard	50 ~ 120% Flow Rate
	Ent/Lev Temperature	32°C/40°C, 85F/104F	15 ~ 35°C (Pls contact to Carrier if any special requirements)
	Fouling Factor	< 0.086 m ² ·°C/kW	> 0.086 m ² ·°C/kW
	Max Pressure	10 barG (1.0Mpa)	16 or 20 bar
	Water Quality	Fresh Water	Sea Water or Brine(Ethyleneglycol)
Steam or Hot Water	Flow Rate	See a Physical & Performance data sheet	50 ~ 120% Flow Rate
	Steam Pressure	1.0 barG (0.98Mpa)	Pls contact to Carrier if any special requirement
	Hot Water Temperature	See a Physical & Performance data sheet	
	Fouling Factor	Below 0.086 m ² ·°C/kW	Above 0.086 m ² ·°C/kW
	Max Pressure	10 barG (1.0Mpa)	16 or 20 bar
Power Supply	Voltage x Hz x Ph	380V x 50Hz x 3Ph	220V, 400V, 440V, 460V / 60Hz
Control Panel	Type	PLC	Weather Proof or Explosion Type
Control Valve	Type	Electric Actuator	Auto-Spring Return or Pneumatic Actuator
	Control Signal	4 - 20mA	0 - 10dV
	Capacity Range	10 - 100%	
Safety Device	Low Chilled Water Temperature Switch Low Chilled Water Flow Switch High Temperature Switch @Generator High motor Temp. and Current of Sol. & Ref. Pump	Cooling Water Flow, Flow Switch	
Painting Color	Carrier Green Gary	Pls contact to Carrier if any special requirement	
Purge System	Auto-Purging	Pd-Cell	
	Purge Chamber, Vacuum Pump and Manometer		
Heat Transfer Tube	Copper Tube	Copper Nickel(90:10 & 70:30)	
A/C & E		Titanium for Sea Water	
Code	GB Standard	CE, UL or PED, ASME (pls contact to Carrier)	
Shipping	1-Piece	2-Piece	
Thermal insulation	Job Site	Factory Insulation	

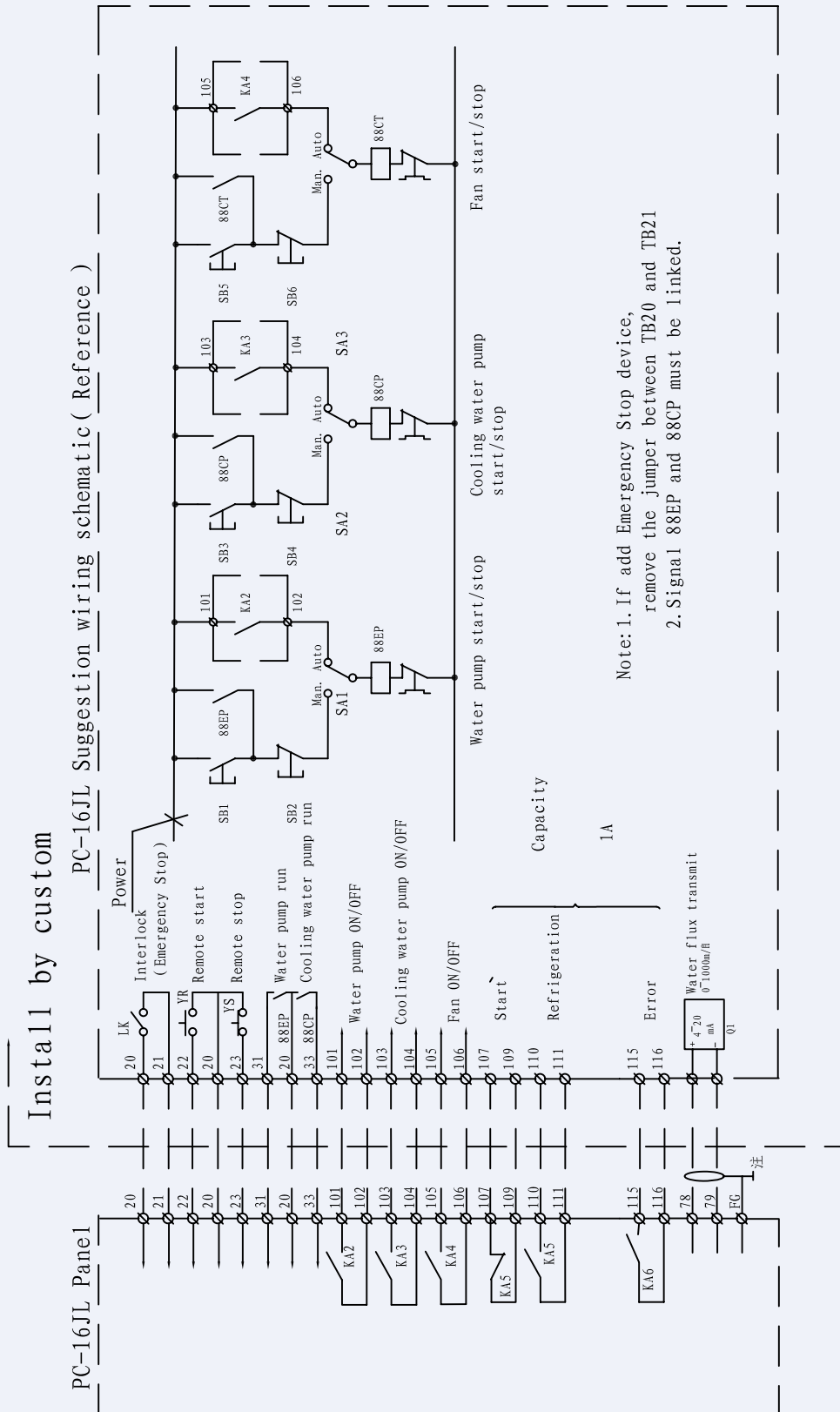

Standard Tubing Flow

16JL

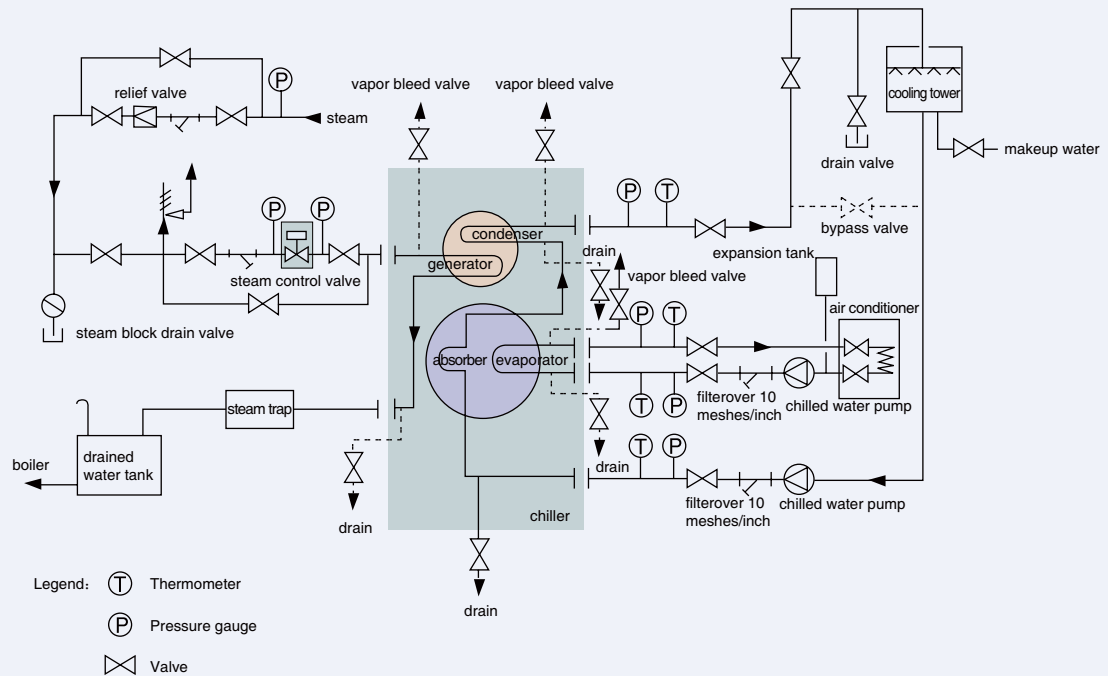

Description of standard tubing flow:

1. Equipment supplied by Carrier is within the scope of " " in flow chart.
2. Please fit thermometer and pressure gauge at inlet/outlet of water tube where it is convenient to observe.
3. Each chiller shall be configured with independent chilled water pump and cooling water pump.
4. Positions of chilled water pump and cooling water pump and expansion tank shall take account of water level difference and static pressure to ensure the gauge pressure of the chiller does not exceed 0.8MPa.
5. Chilled water and cooling water flow shall meet the specification. It is also allowed to install a flow meter on chilled water tube for the convenience of operation control.
6. If cooling water inlet temperature tends to decrease to below 15°C, a bypass valve shall be installed at the place where it is indicated with dashed line to maintain such temperature higher than 15°C.
7. If steam pressure (gauge pressure) exceeds 0.098MPa (inlet pressure of the chiller), a relief valve shall be installed at the place indicated in the figure.

Standard Tubing Flow

16JLR

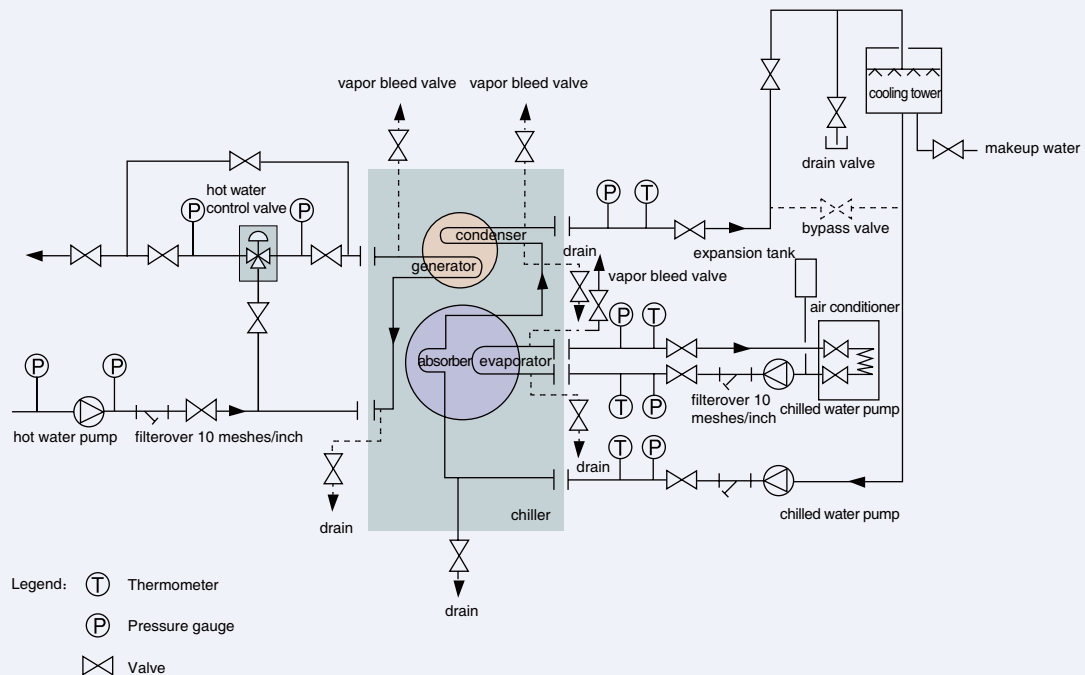

Description of standard tubing flow:

8. A steam control valve shall be installed in front of 16JL chiller (such steam valve is supplied by Carrier). Pressure gauges with a range of 0–0.2MPa shall be installed in front of and behind steam control valve respectively. To facilitate detection and maintenance, it is recommended to install bypass line fitted with manual valve at the place of steam control valve.
9. A hot water control valve shall be installed in front of 16JLR chiller (such hot water valve is supplied by Carrier). Pressure gauges with a range of 0–0.8MPa shall be installed in front of and behind hot water control valve respectively. To facilitate detection and maintenance, it is recommended to install bypass line fitted with manual valve at the place of hot water control valve.
10. If temperature of steam or hot water exceeds 130°C, measures shall be taken to reduce the temperature.
11. Flange of chilled water, cooling water and steam (or hot water) tube (single piece) connected with the chiller shall be supplied by Carrier Flange connected with the field piping shall be provided by customer.

Water Quality Control

Water quality control is a key point of maintenance for chiller. Problem such as dirt, sludge or corrosion may occur due to poor water quality. In addition, water quality of the same source will change along with time change (refer to the following table). For example, when cooling water flows through cooling tower, water content may be lost and evaporated into atmosphere. Cooling water gradually becomes concentrated and deteriorated. Cooling water quality degradation may cause corrosion and scaling, which will lead to attenuation of refrigeration capacity of chiller and failures, such as corrosion of heat transfer tube. Therefore, water quality shall be controlled properly, such as setting drainage facility and adding water on a regular basis. Better effect will be obtained if appropriate water treatment additive is available. The following table shows relevant water quality benchmarks for chiller for reference.

Quality benchmarks for chilled water, cooling water and makeup water

Item	Cooling water system			Chilled water system		Trend			
	Circulation type		Direct flow			Corrosion	Scale		
	Circulating water	Makeup water	Direct flow water	Circulating water ≤20℃	Makeup water				
Benchmark item	pH(25℃)	6.5~8.2	6.0~8.0	6.8~8.0	6.8~8.0	6.8~8.0	○	○	
	Conductivity	(mS/m) (25℃)	≤80	≤30	≤40	≤40	≤30	○	○
		[μS/cm] (25℃)	[≤800]	[≤300]	[≤400]	[≤400]	[≤300]		
	Chlorine ion Cl ⁻ (mgCl ⁻ /l)	≤200	≤50	≤50	≤50	≤50	○		
	Sulfate ion (mgSO ₄ ²⁻ /l)	≤200	≤50	≤50	≤50	≤50	○		
	Acid consumption (PH4.8)(mgCaCO ₃ /l)	≤100	≤50	≤50	≤50	≤50		○	
	Full hardness (mgCaCO ₃ /l)	≤200	≤70	≤70	≤70	≤70		○	
	Calcium carbonate hardness (mgCaCO ₃ /l)	≤150	≤50	≤50	≤50	≤50		○	
Ion state silicon dioxide (mgSiO ₂ /l)	≤50	≤30	≤30	≤30	≤30		○		
Reference item	Iron (mgFe/l)	≤1.0	≤0.3	≤1.0	≤1.0	≤0.3	○	○	
	Copper (mgCu/l)	≤0.3	≤0.1	≤1.0	≤1.0	≤0.1	○		
	Sulfur ion (mgS ²⁻ /l)	Cannot be detected					○		
	Ammonium ion (mgNH ₄ ⁺ /l)	≤1.0	≤0.1	≤1.0	≤1.0	≤0.1	○		
	Residual chlorine (mgCl/l)	≤0.3	≤0.3	≤0.3	≤0.3	≤0.3	○		
	Free carbon (mgCO ₂ /l)	≤4.0	≤4.0	≤4.0	≤4.0	≤4.0	○		
	Stability index	6.0~7.0	—	—	—	—	○	○	

Note: "○" mark in the column indicates relevant factor prone to corrosion or scale

Water Quality Control

Quality benchmarks for chilled water, cooling water and makeup water

	Item	Hot water	Makeup water	Trend		
				Corrosion	Scale	
Benchmark item	pH(25°C)	7.0~8.0	7.0~8.0	○	○	
	Conductivity	(mS/m) (25°C)	≤30	≤30	○	○
		[μS/cm] (25°C)	[≤300]	[≤300]		
	Chlorine ion Cl ⁻ (mgCl ⁻ /l)	≤30	≤30	○		
	Sulfate ion (mgSO ₄ ²⁻ /l)	≤30	≤30	○		
	Acid consumption(PH4.8) (mgCaCO ₃ /l)	≤50	≤50		○	
	Full hardness (mgCaCO ₃ /l)	≤70	≤70		○	
	Calcium carbonate hardness (mgCaCO ₃ /l)	≤50	≤50		○	
Ion state silicon dioxide (mgSiO ₂ /l)	≤30	≤30		○		
Reference item	Iron(mgFe/l)	≤1.0	≤1.0	○	○	
	Copper(mgCu/l)	≤1.0	≤1.0	○		
	Sulfur ion (mgS ²⁻ /l)			○		
	Ammonium ion(mgNH ₄ ⁺ /l)	≤0.1	≤0.1	○		
	Residual chlorine (mgCl/l)	≤0.3	≤0.3	○		
	Free carbon (mgCO ₂ /l)	≤4.0	≤4.0	○		
	Stability index	—	—	○	○	

Note: "○" mark in the column indicates relevant factor prone to corrosion or scale

Carrier Corporation identified six specific areas of concentration that directly impact how we, as a world manufacturer, balance our customers' needs for comfort with the environment's needs for responsible consumption.

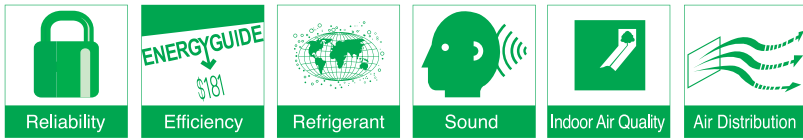

The Manufacturer reserves the right to change any product specifications without notices

© All Rights Reserved Carrier

T-16JL/R-0710-01(E)-CHK